

## PREPARE TO BE PARED!

Double the fun comes to those who wait. After a four-year hiatus, a new Artport exhibit will be revealed in the corridors of the Shreveport Regional Airport and the DATE HAS BEEN SET – THURSDAY, FEBRUARY 9, 2012.

## NEW CALENDAR

- September 15 ..... Public Call for Entries
- September 12 – 30 ..... Drop off \$200 sponsorship monies and pick up tiles at Kalmbach Smith Meadows – 1530 Fairfield Avenue. Please enter through the front door and sign for your materials and payment receipt.
- September 30 ..... Deadline for public call. There are \_\_\_ spaces open.
- October 19 - 26 ..... Pick up canvas at Kalmbach Smith Meadows – 1530 Fairfield Avenue. Please enter through the front door and sign for your materials.
- Oct - Jan ..... Committee Meetings: See schedule below.
- December 12 - 13 ..... Remove artwork from Shreveport Regional, load and transfer to Neil Johnson's studio
- December 14 ..... Delivery of new artwork & tiles to Neil Johnson's studio; pick-up 2007 artwork and sit for head shot. (There will be a make-up date announced)
- February 9 ..... Set-up at Shreveport Regional Airport 1-5pm.
- February 9 ..... "PAIRED" opening reception at the Shreveport Regional Airport, 6-9pm; mandatory arrival at 5:00pm for group activities

## THEME

The theme this year is "PAIRED" and all artwork should reflect a partnership theme, but is open to interpretation by the artist. Each artist will receive two vertical canvases for their work. The painting can cross the plane of the canvases or they can be used separately, yet together to follow the theme (see guidelines for specifications).

## ELIGIBILITY

Artport is open to all professional and emerging professional artists in the Ark-La-Tex region. New artists are welcome and encouraged to apply! Due to the growing amount of new artist interested in participating in the upcoming show, and the limited amount of wall space at Shreveport Regional Airport, Artport has established a jury committee to determine the eligibility of new artists wishing to show. The jury is comprised of a diversified group of individuals reflecting the art community, art consumers, business professionals from outside the Ark-La-Tex region, and the Artport president. Artists that participated in the previous Artport 2007 show will have first right of refusal to enter the show again and are exempt from the jury process. The jury will fill the remaining positions available and notify these individuals through written correspondence.

## ENTRY

Sponsorship: Each artist is responsible for a sponsorship of his/her work in the amount of \$200. The sponsorship may be a business or individual, and is not limited to the number of contributors. The sponsors will be listed in the 2012 Artport limited edition color catalog. The \$200 sponsorship helps cover the costs of not only the Artport opening reception, but also the canvases and tiles provided to the artists, and the printing of the Artport color catalog. The sponsorship is not optional and **MUST BE PAID IN FULL** upon pick-up of the tile.

## TILES

In lieu of an entry fee, all artists must submit a separate work of art on an 6x6 ceramic tile to be auctioned at the opening reception. Tiles are free and may be picked up at the offices of Kalmbach Smith Meadows at 1530 Fairfield Ave. between September 12 - 30. Tiles will not be mailed to artists; and the artists who do not submit a tile will forego entry into the show. Each artist should also submit a two-paragraph biography to be included on the Artport website and in the Artport color catalog, a collection of the artists' work.

All proceeds of these tiles will benefit The Betty and Leonard Phillips Deaf Action Center. The Deaf Action Center was selected as this year's charity of choice for Artport. Each Artport showing will benefit a select philanthropic community effort. Artport has raised over \$75,000 in this event for other charities.

## DELIVERY OF ENTRIES

Deliver artwork to Neil Johnson's studio at 1301 Louisiana Avenue on December 14. Artists will sign in their artwork for the 2012 show, sit for a professional photograph with Neil Johnson, and collect the 2007 painting. Professional headshots of the artist and their artwork will be used for publication and the official Artport website **HYPERLINK** "<http://www.artportshreveport.com>" [www.artportshreveport.com](http://www.artportshreveport.com). Make-up days will be announced.



## GUIDELINES (see guideline illustration sheet)

All guidelines must be met or the artwork will be disqualified without notice.

- Artwork must have been created since October 2011.
- Only one piece (two 15 x 36 canvases) may be exhibited from each artist.
- Size: Artwork must be completed on the provided 15 x 36 canvases and in a vertical format. ANY ARTWORK NOT ORIENTED VERTICALLY WILL BE DISQUALIFIED. HORIZONTAL PIECES WILL NOT BE ACCEPTED.
- Content can be pairings of two different images on each canvas or an image spread across the two canvases to make one.
- The artist may select which medium they prefer to paint on the canvas i.e. watercolor, acrylics, collage, etc.
- Artwork should not be framed. Artwork canvas should be in gallery format. Plexiglass is optional for protection of color and watercolors. For safety concerns, no glass will be accepted.
- The two canvases will be presented to the artist with proper hanging hardware installed.
- No nudity, obscenity or politically sensitive or offensive content will be accepted.



## LIABILITY

All reasonable care will be given to the artwork. A regular maintenance agreement has been signed by both the Shreveport Regional Airport and the Artport organizers. All works are submitted at the artist's risk and neither the Shreveport Regional Airport nor the Artport organizers will be held accountable for any possible damage.



## SALES & REPRODUCTION

Artwork may be for sale in the exhibit. All artwork will be tagged with an ID card that lists the artist's name, name of the piece and Artport contact information for sale of the piece. This number will route directly to Kalmbach Smith Meadows, who will coordinate the exchange of the artwork, as well as the commission payments. With the sell of artwork, you must replace it with a work of exact size. Artport is granted a 25% commission from the sale to help defray the cost of future Artport events. This commission is mandatory and will be monitored by Kalmbach Smith Meadows. Artport reserves the right to reproduce art for printing, internet and publicity purposes.

**Artport Committee Meetings will be held monthly.** Please mark your attendance for each date and return via fax to 227-9830.

MONDAY, NOVEMBER 14 @ 10:30am     Attending     Not Attending  
 MONDAY, JANUARY 9 @ 10:30am     Attending     Not Attending

Individual committee groups will be encouraged to meet on their own to facilitate projects and report at monthly meetings. Meetings are subject to change. Reminder notices will be sent via email.

 **FOR MORE INFORMATION CALL:**  
Kalmbach Smith Meadows. 318-227-8611



**CORRECT CANVAS ORIENTATION**

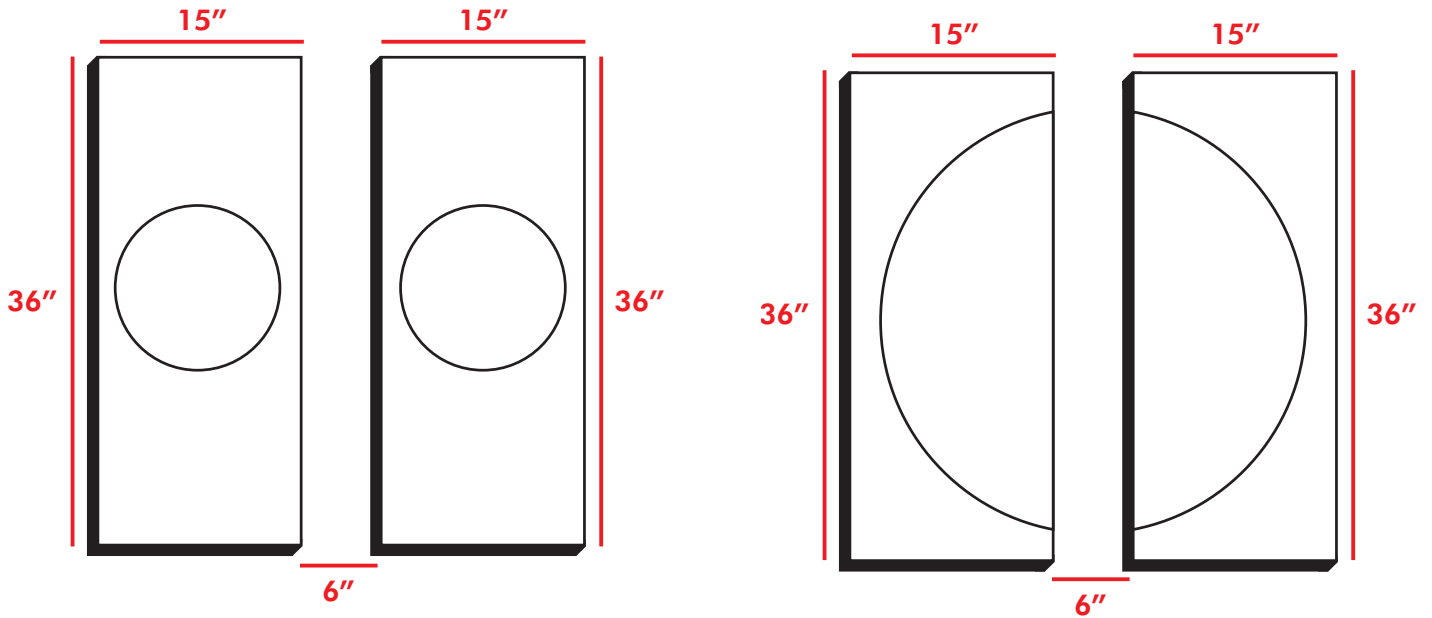

**INCORRECT CANVAS ORIENTATION**

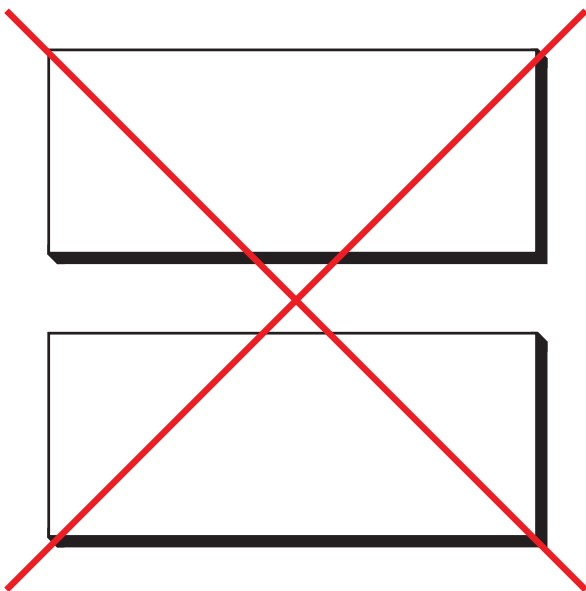

**INCORRECT CANVAS SPACING**

